

# CONFIDENTIAL

MG / 288

## SERVICE MEMORANDUM cancelling MG/282

13 Nov. 1959

### REMEDIES FOR POSSIBLE COMPLAINTS

'MGA' TWIN CAM

#### Lack of power

The following should be checked:

Fuel: A minimum of 95-octane is desirable, but, if this is not available, fuels down to 90-octane can be used, provided the ignition setting is adjusted as detailed below. Fuels below 90-octane should not be used.

Valve timing: (see Workshop Manual section A 19).

Ignition setting: This must be maintained at top dead centre for fuels of 95-octane and over. For 90/95-octane fuels the ignition should be set to  $2^{\circ}$  -  $3^{\circ}$  A.T.D.C. (Make sure the distributor points are adjusted to .015" first as this will vary the setting.)

Carburettor setting and needle type (OA6):

Tappet setting: .014" to .015" must not be exceeded.

Sparking plugs: for condition and correct type.

Champion N.3 for all normal use (Part No. 97H611);

Champion N.58R for competition work (Part No. 97H2275).

Carburettor damper pistons:

Improved performance is obtainable with new damper AUC8114. Dampers in both carburettors must be identical (PMG/347 and Service Memorandum No. MG/264 refer).

Air cleaners:

In the case of the first 28 cars it is possible for the elements in the air cleaners to move out of position and foul the carburettor inlet.

The remedy is to spot-weld a piece of .031" thick steel strip,  $1\frac{3}{4}$ " long and with turned ends, to the air cleaner inner bracket, as shown in the accompanying sketch.

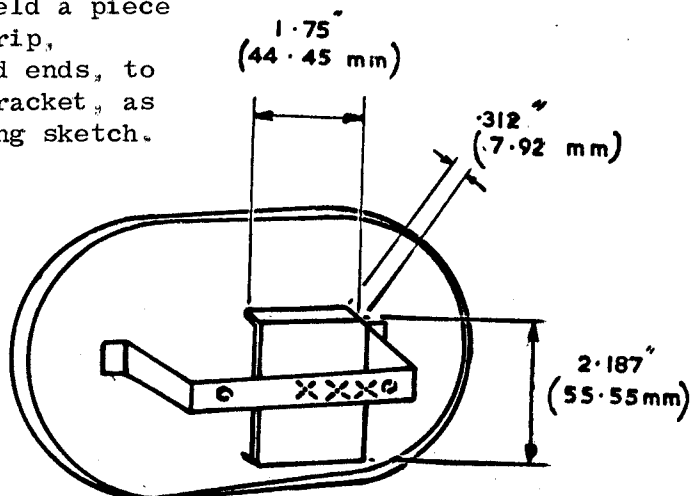

P.T.O.

Piston holing:

This is usually the result of over-advance of the ignition, use of incorrect sparking plugs, incorrect grade of fuel or a combination of the three.

The engine is a high compression, high output unit and any additional ignition advance from the required settings will give excessive sparking plug and combustion temperatures, with consequent possibilities of damage to the pistons.

In order to ensure correct ignition timing throughout the speed range of the engine, it is essential that the distributor advance mechanism should be checked by using a stroboscopic timing light to observe the amount of distributor advance (with the vacuum advance disconnected) for various engine speeds.

The observed amount of advance should be within the limits specified in the following table:

CRANKSHAFT R.P.M.	2,000	3,000	4,000	5,000
MAXIMUM ADVANCE	24°	26°	26°	26°

If the above figures are exceeded, the static ignition setting may be retarded to a maximum of 3° A.T.D.C. If this does not give the required figures, the distributor should be replaced. If the advance is still excessive, the distributor drive gears Part Nos. AEH500 & AEH450, should be renewed. In order to prevent any excessive ignition advance, the vacuum advance pipe should be permanently disconnected and the union on the manifold blanked off, using blanking plug Part No. AUC1289. The vacuum union on the distributor must be left open to the atmosphere.

Champion N.3 sparking plugs (Part No. 97H611) MUST be used for all normal work. A lower grade (hotter running) plug MUST NOT be used, as incipient detonation, due to a rise in plug and combustion temperatures, might occur and result in serious damage to the engine.

For competition purposes, where a high output is sustained, Champion N.58.R sparking plugs (Part No. 97H2275) should be used. These will ensure that combustion temperatures are not excessive and allow an increased margin of safety.

Due to the high compression ratio of the engine, premium fuels of not less than 95-octane rating are recommended; lower grades of fuel will result in excessive combustion temperatures, unless the ignition setting is adjusted to 2° - 3° A.T.D.C.

For maintenance of peak efficiency, it is preferable to use the Super-grade fuels of 100-octane rating.

Distributor clamping:

Excessive wear has occurred in the distributor driving gears on some engines, due to misalignment of the distributor with its drive, causing a tightening-up of the distributor shaft and consequent excessive gear loading and gear wear.  
See Service Memorandum No. MG/248.

Excessive oil consumption:

Earlier engines were fitted with scraper rings without expander rings and in cases of reported heavy oil consumption the twin-segment scraper ring AEH672 (which included the expander ring) should be fitted. Provided this expander ring is used in conjunction with the twin-segment scraper ring, no oil consumption troubles will be experienced. Oil consumption in the order of 1,500 miles per gallon should be obtained after (say) 1,000 miles. The expander rings were fitted from Engine No. 2057.

The latest piston assembly, including expander ring, is obtainable under Part No. AEH673.

Oiling-up of sparking plugs

This could be due to use of incorrect type of plugs, or to the engine being fitted with scraper rings without expanders.  
If the correct piston scraper rings and the correct type of plug (Champion N.3) are fitted, oiling-up should not occur in normal use.

Running-on

It must be ensured that no sharp edges of any kind are present in the combustion chambers, especially around the sparking plug apertures.

Carburettors must be set to give the minimum slow-running, with accurate and equal setting of each throttle.

Tappet failure

Originally the tappets were short and ran in the aluminium head. With these, ridging of the bores and tappet jamming can occur.

A longer tappet, Part No. AEH651, was fitted at Engine No. 1087. This can be used to replace the short tappet if the bores are satisfactory.

From Engine No. 1587, cast-iron sleeves for the tappets to run in were added to the cylinder head to increase the life of the tappet bores. These can only be fitted satisfactorily in production.

### Camshaft failure

Camshaft breakage may be due to incorrect bolting down of the camshaft bearing caps (see below).

Overloading may also occur if the recommended tappet setting of .014" to .015" is exceeded.

Note: Particular attention is drawn to the revised tappet clearances. All Service Literature is being altered accordingly.

### Fitting of camshaft bearing caps

To ensure that no distortion of the camshafts takes place, the camshaft bearing cap nuts should be tightened strictly in accordance with Service Memorandum No. MG/251.

### Vibration

This was experienced on early power units and was cured by accurate balancing (see Service Memoranda Nos. MG/252 and MG/262).

### Half-speed shaft

Any excessive increase in end-clearance of the half-speed shaft advances the ignition. This end-clearance can be maintained at the correct dimension of .003" to .006" by altering the shims fitted behind the half-speed shaft locating plate (see Workshop Manual, section A30, page A16).

### Chain tensioner - adjuster bolt stripping

The length of thread in the housing has now been increased.

If the thread is slack or damaged, a new chain adjuster, Part No. AEH27, should be fitted.